

TECHNICAL DATA

SINGLE DRUM ROLLERS

BW 226 DH-5, BW226 PDH-5

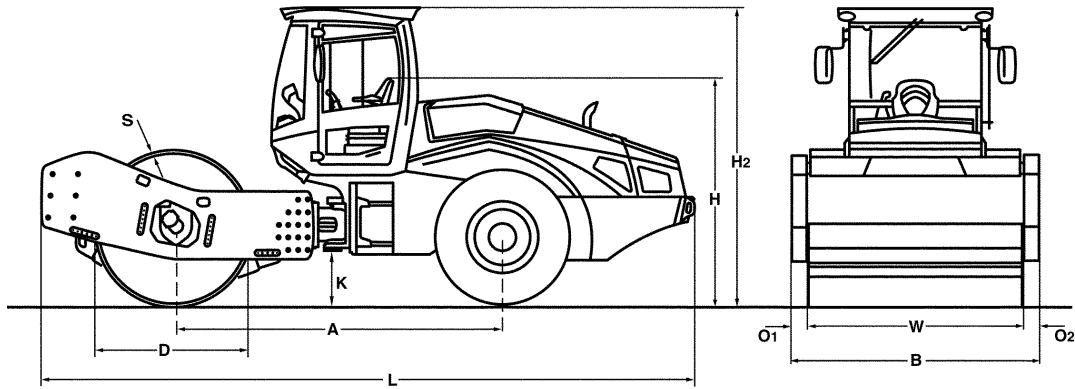



Dimensions in mm

	A	B	D	H	H2	K	L	O1	O2	S	W
BW 226 DH-5	3360	2500	1600	2350	3080	430	6740	185	185	40	2130
BW226 PDH-5	3360	2500	1500	2340	3080	430	6740	185	185	35	2130

Shipping dimensions in m3

BW 226 DH-5
BW226 PDH-5

without ROPS

39,598
39,429

with ROPS

51,898
51,898

Machine type	Compaction output (m3/h)			
	Rock fill	Gravel, sand	Mixed soil	Silt, clay
BW 226 DH-5	1180-2120	880-1750	680-1200	350-700
BW226 PDH-5	1180-2120	1180-2120	810-1550	450-890

Machine type	Compacted layer thickness (m)			
	Rock fill	Gravel, sand	Mixed soil	Silt, clay
BW 226 DH-5	2,00	1,50	1,00	0,50
BW226 PDH-5	2,00	2,00	1,50	0,80

Technical Data**BOMAG
BW 226 DH-5****BOMAG
BW226 PDH-5****Weights**

Grossweight	kg	26.710	27.500
Operating weight CECE w. ROPS-cabin	kg	25.000	25.740
Axle load, drum CECE	kg	17.070	17.800
Axle load, wheels CECE	kg	7.930	7.940
Static linear load CECE	kg/cm	80,1	

Dimensions

Working width	mm	2.130	2.130
Track radius, inner	mm	4.260	4.260

Driving Characteristics

Speed	km/h	0- 10,0	0- 10,0
Max. gradeability without/with vibr.	%	50/47	52/49

Drive

Engine manufacturer		Deutz	Deutz
Type		TCD 2012 L06	TCD 2012 L06
Emission stage		Stage IIIa / TIER3	Stage IIIa / TIER3
Cooling		water	water
Number of cylinders		6	6
Performance ISO 3046	kW	150,0	150,0
Performance SAE J 1995	hp	202,0	202,0
Speed	min-1	2.200	2.200
Fuel		Diesel	Diesel
Electric equipment	V	12	12
Drive system		hydrost.	hydrost.
Drum driven		standard	standard

Drums and Tyres

Tyre size		23.5-25 16PR	750/65 R26
Number of pad feet			150
Height of pad feet	mm		100
Area of one pad foot	cm2		137

Brakes

Service brake		hydrost.	hydrost.
Parking brake		hydromec.	hydromec.

Steering

Steering system		oscil.artic.	oscil.artic.
Steering method		hydrost.	hydrost.
Steering / oscillating angle +/-	grad	35/12	35/12

Exciter system

Drive system		hydrost.	hydrost.
Frequency	Hz	26/26	26/26
Amplitude	mm	2,10/1,20	1,70/0,90
Centrifugal force	kN	328/187	328/175
Centrifugal force	t	33,5/19,1	33,5/17,9

Capacities

Fuel	l	280,0	280,0
------------	---	-------	-------

Technical modifications reserved. Machines may be shown with options.

Standard Equipment

- BOMAG ECOMODE
- Double pump system for travel drive
- Self locking differential
- Rear axle with twin spring accumulator brakes
- Hydrostatic travel and vibration drive
- Hydrostatic articulated steering
- Articulated joint lock
- Seat with arm rest and adj. for position and height
- Battery disconnect switch
- Single lever control for travel and vibration
- Warning, information and operation displays with LCD
- Loading mode
- Emergency STOP
- Working lights front / rear
- Back-up alarm
- 2 Scrapers
- Warning horn
- Tractor tires (PDH)

Optional Equipment

- ROPS/FOPS cabin with seat belts
 - Sliding window
- Rearview camera
- Air condition
- Radio (Bluetooth)
- Pre start cabin heating
- Comfort package: Adjustable seat and adjustable steering column
- Rotary beacon
- Indicator and hazard lights
- BOMAG ECOSTOP
- ECONOMIZER
- TERRAMETER
- BOMAG TELEMATIC POWER
- Special painting
- Padfoot segment kit (DH)
- Measuring- and machine data interface for third-party suppliers
- Reversing alarm buzzer with broad band audio
- LED Working lights (Cabin)
- Highly wear resistant drum
- Rock tyre

